

Specification Data Sheet

Rev 1.1 October 2016

Armour Home Electronics R&D Department

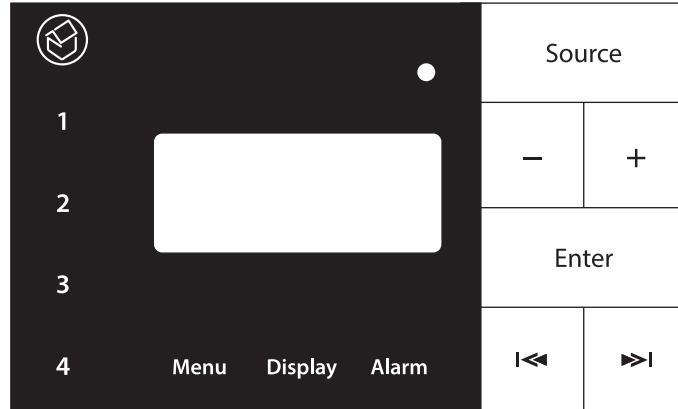

Systemline E100 is an integrated fitted music system which includes an OLED display and touch sensitive button keypad fitted in the wall. The keypad contains amplification for speakers, DAB/FM tuner, *Bluetooth* audio receiver and auxiliary line input all contained within one 45mm deep double gang wall socket. E100 also includes a clock and alarm and remote control. E100 has been designed to be very easy to install and very user friendly, making it perfect for kitchens and bedrooms, and its IP rating of IP54 makes it suitable for bathrooms as well.

Wiring diagram

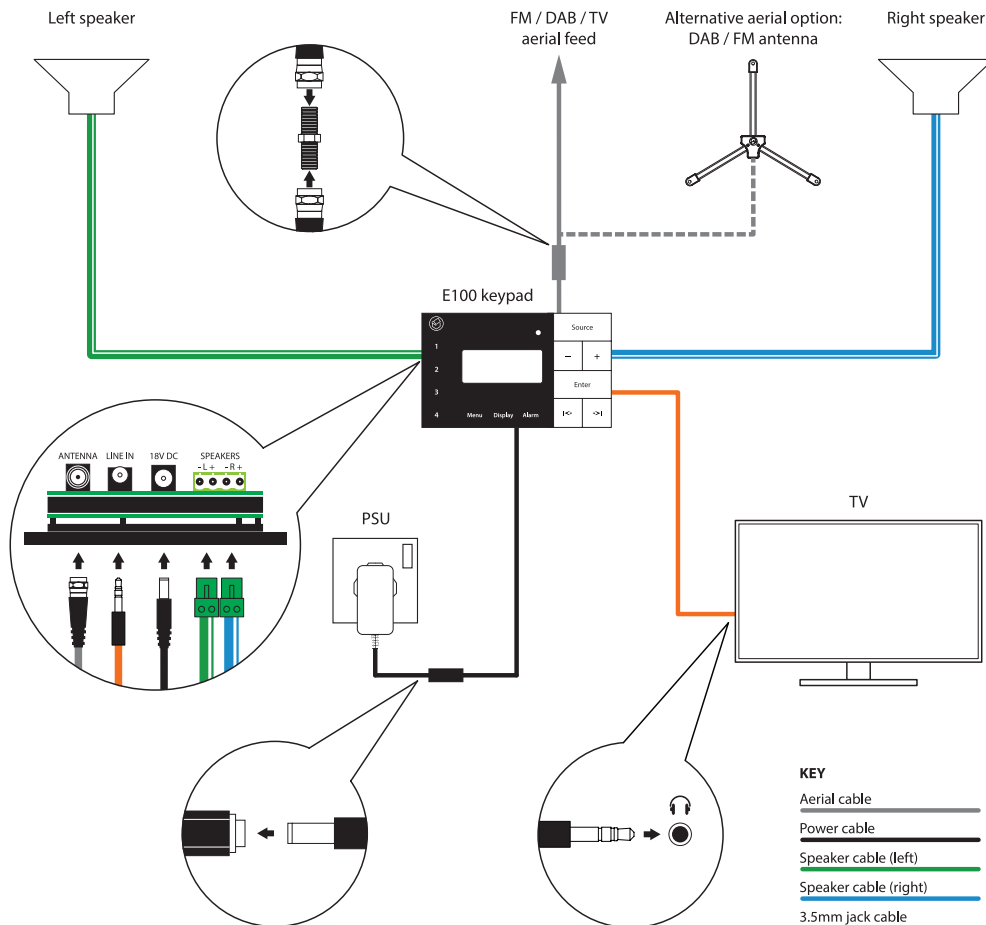

Specifications	
Radio	DAB/DAB+ and FM with RDS 4 preset stations
Bluetooth	Class 2 Bluetooth 2.1 apt-X for CD-quality transmission Secure pairing Passcode Selectable device name to allow multiple units to be used in close proximity Range up to 10m
Aux input	725mV Normal Gain or 250mV Boost Gain
Alarms	2 separate alarms configurable for daily, weekday or weekend operation
Languages supported	English, Chinese, Danish, Finnish, French, German, Italian, Norwegian, Spanish and Swedish
Power output	2 x 18W into 8 Ohms @ 0.5% THD 1kHz
Frequency response	20Hz – 20kHz +/- 1dB
Power supply	110-240 VAC
IP Rating	IP54

